



# Editorial

Welcome to the 3<sup>rd</sup> EMC<sup>2</sup> Newsletter which will provide an impression on selected EMC<sup>2</sup> topics and intermediate results. In this issue we will focus on:

I. Project Progress	1
II. EMC <sup>2</sup> Project Conference	1
III. Teaching Mixed Criticality	3
IV. ARTEMIS Workshop DECSoS at SAFECOMP 2015 and Special Session TET-DEC at Euromicro SEAA/DSD Conference 2015	4
V. Advanced safety in automotive applications	6
VI. EMC <sup>2</sup> Garonne Vehicles at ITS World Congress in Bordeaux	7
VII. EMC <sup>2</sup> at HIPEAC 2016 – 2 <sup>nd</sup> Workshop on Mixed Criticality Applications and Implementation Approaches	8
VIII. EMC <sup>2</sup> Summit 2016 – Call for Papers	9

## I. PROJECT PROGRESS

Beginning of the second project year, the first review meeting took place at Siemens in Munich, Germany. Within the frame of the two days meeting detailed technical presentations on all EMC<sup>2</sup> aspects were given,

many of them accompanied by first demonstrations. The progress achieved during the first year was well perceived by the Project Officer and the reviewers.

End of September 2015 the project reached mid-term. We take this opportunity for a short view on the project progress. None of the challenging EMC<sup>2</sup> objectives needed to be adjusted; all deliverables and milestones were achieved almost in time. Since project start far more than 100 presentations and publications were prepared, accepted and presented. Special sessions on EMC<sup>2</sup> topics were organised in several highly ranked conferences. Selected highlights of dissemination measures are presented via our website [www.artemis-emc2.eu](http://www.artemis-emc2.eu). There, please find detailed material for download, watch EMC<sup>2</sup> videos or just get an impression on the progress by scrolling through the list of publications, presentations and press releases etc.

To conclude: EMC<sup>2</sup>, the giant of research projects, is fully on track.

## II. EMC<sup>2</sup> PROJECT CONFERENCE

For sure, one of the highlights is represented by the project conference. Organized by Dr. Andreas Eckel, TTTech Computertechnik AG, the second EMC<sup>2</sup> project conference was held at the Tech Gate in Vienna at 30th of September 2016.

The conference and workshop week were set-up for EMC<sup>2</sup> project members only and were not open to public in order to allow project partners to openly discuss all project related questions in a well suited environment.

The week starting Monday, Sept. 28<sup>th</sup> up to Oct. 1<sup>st</sup> 2015 was dedicated to the exchange of experiments and other early results, work package meetings and discussions between partners about various topics such as future result sharing and exploitation, solve specific technical problems within and outside of the project, exchange of ideas, valuable networking means, etc. The conference and workshop week has been attended by Industry (large Industries and SMEs), research institutions, and universities in a well-balanced composition, in total 147 participants.



Dr. Andreas Eckel, TTTech

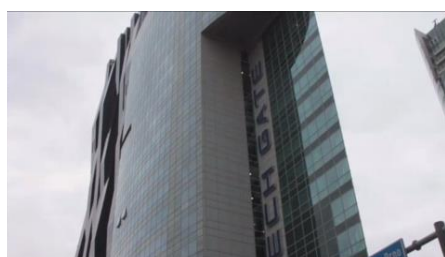

Tech Gate, Vienna, Austria





During the first two days of the work shop week specially dedicated work package meetings were conducted in order to talk about and make decisions concerning the next steps to be mastered in the project as well as to discuss how to optimally monitor and report the progress of the huge EMC<sup>2</sup> project by means of “technology cockpit charts”. Many of the work packages also made use of the opportunity to conduct combined work-package meetings.

The conference day started with 5 key note speeches and a short introduction about TTTech Computertechnik AG, hosting the conference and work shop week. The well received keynote speeches were given by Prof. Hermann KOPETZ, Vienna University of Technology, “On the Cognitive Complexity of Cyber-physical System of Systems”, (b) Dr. Wilfried STEINER, Chief scientist at TTTech, “Deterministic Ethernet - From Oriented Basic Research to a Powerful Technology Portfolio”, (c) Prof. Avi MENDELSON, Technion, “Power Management on Real-time System or any Related Topics”, (d) Prof. Jerker DELSING, Technical University of Luleå, “Service Oriented Architecture results from Arrowhead and its Usage in EMC<sup>2</sup>” and finally Prof. Mladen BEREKOVIC, Technical University Braunschweig, “Models for Mixed Criticality Systems”.

could be demonstrated by means HW/SW demonstrators shown to colleagues. Information from the work packages were disseminated by means of posters. This session enabled networking in an ideal way and paved the way for discussions, both, technically and commercially, and for exchange of ideas.



Poster Session

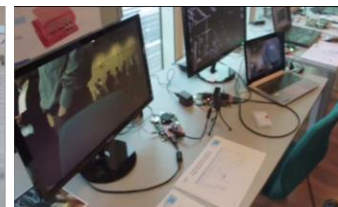

Demonstrations



Dr. Andreas Eckel, Dr. Werner Weber

Finally, the conference day also conducted an interview with the coordinator Dr. Werner Weber, Infineon Technologies AG. The interview was

used for the conference video including impressions and clippings from the speeches and the poster & demonstrator session. The power point slides as well as a full video recording of the key note speeches and the conference video are available on the EMC<sup>2</sup> home page ([www.artemis-emc2.eu](http://www.artemis-emc2.eu)).



Prof. Hermann Kopetz

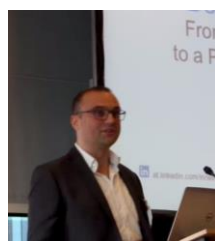

Dr. Wilfried Steiner



Prof. Avi Mendelson



Prof. Jerker Delsing



Prof. Mladen Berekovic



“Lusthaus”, Viennese Prater



After the conference a networking dinner was organized in the famous “Lusthaus” located in the Viennese Prater. The old building first was mentioned in 1560 in the times of Emperor Maximilian II, where the Lusthaus was used as one of the Emperor’s hunting residences. In 1766 Emperor Josef II opened up the Prater for public. Since then the Lusthaus was a popular place for celebrations and it still is.

Following the key note speeches, EMC<sup>2</sup> partners prepared a poster and demonstrator session, where results

### III. TEACHING MIXED CRITICALITY



*Dr. Frank Oppenheimer, OFFIS e.V.*

This article is about teaching Mixed-Criticality. Dr. Frank Oppenheimer and his team from OFFIS e.V. presented a paper at the ESWeek'15 Workshop on Embedded and Cyber-Physical Systems Education (WESE).

Modern Cyber-Physical Systems (CPS) already integrate multiple functions and this trend is expected to grow in the near future for economic reasons. If these different functions are of different importance for the behavior of a safety relevant CPS, we talk about Mixed-Criticality Cyber-Physical Systems (MC-CPS). In general, a mixed-criticality system contains computer hardware and software that can execute several applications of different criticality, such as safety-critical and non-safety critical, or of different Safety Integrity Level (SIL). These different applications are engineered to different levels of assurance, with high criticality applications being the most costly to design and verify. MC-CPS are typically embedded in machines such as an aircraft, train or car whose safety must be ensured.

In many domains such as automotive, avionics and industrial control, the future economic success depends on the ability to design, implement, qualify and certify advanced MC-CPS within bounded time, effort and costs. Without appropriate preconditions, the integration of applications of different criticalities will lead to a significant and potentially unacceptable increase of engineering and certification costs. There are several ongoing research initiatives studying mixed-criticality integration in single and multicore processors, as well as on distributed systems. Key challenges are the combination of virtualization, segregation and the extension of partitioning mechanisms jointly addressing significant extra-functional requirements (e.g., time, energy and power budgets, adaptivity, reliability, safety, security, volume, weight, etc.) along with a proven development and certification methodology.

As described above, the engineering of MC-CPS requires competences from different disciplines, such as physics,

mechatronics, electrical engineering, embedded HW/SW design, real-time systems, software engineering, control theory and safety analysis. Most of these disciplines are covered by university courses, but the application of these techniques on the design of a real MC-CPS can hardly be handled in a regular course.



*Considered multi-rotor MC-CPS*

At the Carl von Ossietzky University of Oldenburg, a Project Group (PG) is a course from the Master's curriculum at the department of computer science that takes two semesters (one year), where a group of 6 - 12 students performs a complete project. Starting from a given problem definition, the overall goal is to perform from the problem analysis to the complete realization of the solution.

In addition to methods and contents of their study subject, students learn job-specific procedures and personal skills, such as preparation of content, targeted argumentation, presentation and judgment. Furthermore, the following skills are taught: Working as a team; Taking responsibility; Project planning with division of labor and cost analysis; Dealing with hardly manageable problems; Independent acquisition of partial solutions; Introducing and defending ideas and proposals before the group; Extensive documentation; Working with tools, standards and quality assurance measures.

The industry calls for general skills in graduates, especially independence, teamwork and the ability to evaluate ideas, processes and products to an increasing extent. These qualifications are strongly supported in a PG, which does not dispense with "hard" skills and





individual performance. The self-determined work in the project and the creation of a "real" product have very positive effect on the motivation, the enthusiasm and creativity. Through group work and the associated frequent lectures, students learn to present their own ideas and to convey their own ideas in a group. At the same time, this group work strengthens the self-assessment and self-confidence of the members.

In the WESE'15 paper titled "Teaching Mixed-Criticality: Multi-Rotor Flight Control and Payload Processing on a Single Chip", the concept, organization, technical outcomes and discussion of the experiences of a two-semester student PG "Avionic Architecture" (see <https://www.uni-oldenburg.de/avionic-architecture>) on teaching the interdisciplinary and crosscutting topic of mixed-criticality within a traditional technical computer science curriculum is presented. The group performed the specification, implementation and test of a mixed-criticality multi-rotor system: Integrating a safety-critical flight control algorithm with a mission-critical payload processing on a single chip. The topic of this PG was inspired by an industrial use-case in the European research project CONTREX (Design of embedded mixed-criticality CONTRol systems under consideration of EXtra-functional properties) and will be continued within the EMC2 project. The execution of the PG has been in close cooperation between the University of Oldenburg and OFFIS - Institute for Information Technology.

The paper will be presented at the ESWeek'15 workshop on "Embedded and Cyber-Physical Systems Education" (WESE), held in October 8, 2015 in Amsterdam, The

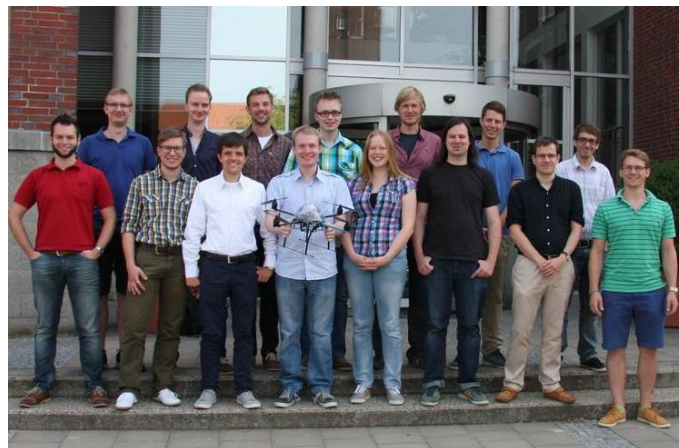

Members of the PG Avionic Architecture: Rear row: André Schaadt, Thomas Nordlohne, Niklas May-Johann, Markus Wieghaus, Martin Bornhold, Marco Braun, Malte Metzdorf (Betreuer); Front row: Henning Schlender (supervisor), Jörn Bellersen, Patrick Schmale, Henning Elbers, Jenny Röbesaat, Steven Schmidt, Sebastian Vander Maelen, Sören Schreiner (supervisor)

Netherlands. The program is available at <http://www.emsig.net/conf/2015/wese/>.

The full paper becomes available after the workshop:

Henning Schlender, Sören Schreiner, Malte Metzdorf, Kim Grüttner, Wolfgang Nebel: **Teaching Mixed-Criticality: Multi-Rotor Flight Control and Payload Processing on a Single Chip**, In *Proceedings of the 2015 Workshop on Embedded and Cyber-Physical Systems Education (WESE)*, October 8, 2015 in Amsterdam, Netherlands

#### IV. ARTEMIS WORKSHOP DECSoS AT SAFECOMP 2015 AND SPECIAL SESSION TET-DEC AT EUROMICRO SEAA/DSD CONFERENCE 2015



Erwin Schoitsch, AIT

The already well established ERCIM/EWICS/ARTEMIS Workshop on Dependable Embedded Cyber-physical Systems and Systems-of-Systems" (DECSoS) at SAFECOMP 2015 (Sept. 22-25, 2015) took place this year in Delft, The Netherlands, as full-day workshop on Sept. 22.

Since it was established in 1979 by the European Workshop on Industrial Computer Systems, Technical Committee 7 on Reliability, Safety and Security (EWICS TC7), SAFECOMP has contributed to the progress of the state-of-the-art in dependable application of computers in safety-related and safety-critical systems. SAFECOMP is an annual event covering the experience and new trends in the areas of safety, security and reliability of critical computer applications.

It provides ample opportunity to exchange insights and experience on emerging methods, approaches and





practical solutions. The next SAFECOMP 2016 will take place in Trondheim, Norway, 20.-23. Sept. 2016. It is organized by Amund Skavhaug, NTNU, supported by Erwin Schoitsch, AIT. ([www.safecomp.org](http://www.safecomp.org)).

The DECSoS Workshop comprised 4 Sessions besides the overview and introduction to the CPS initiatives of the EC, ARTEMIS projects, ERCIM and EWICS, by Erwin Schoitsch:

- Introduction, and Safety & Cyber – Security Co-assessment (3 papers)
- Robotics and Motion Control (3 papers)
- Modelling, Testing and Verification (3 papers)
- Dependability and Scalability (2 papers)

The workshop was co-hosted by the following ARTEMIS Embedded Systems/CPS projects, which were represented by papers (besides a few other presentations):

- EMC2 “Embedded Multi-Core systems for Mixed Criticality applications in dynamic and changeable real-time environments”, <http://www.artemis-emc2.eu/>
- CRYSTAL “Critical Systems Engineering Factories”, <http://www.crystal-artemis.eu>,
- ARROWHEAD “Ahead of the Future”, <http://www.arrowhead.eu/>,
- R5-COP “Reconfigurable ROS-based Resilient Reasoning Robotic Cooperating Systems”, <http://www.r5-cop.eu/>
- MBAT “Combined Model-based Analysis and Testing of Embedded Systems”, <http://www.mbat-artemis.eu> and
- nSafeCer “Safety Certification of Software-intensive Systems with Reusable Components”, <http://www.safecer.eu>.

ARTEMIS was one of the European, industry-driven research initiatives and is now part of the ECSEL Joint Technology Initiative (JTI). The current ARTEMIS projects will, however, be continued according to the ARTEMIS rules, but managed by the ECSEL JU. The workshop was very successful and led to interesting discussions, providing a good overview on current work and future perspectives. Details are available on request from [erwin.schoitsch@ait.ac.at](mailto:erwin.schoitsch@ait.ac.at).

The proceedings have been published by Springer as SAFECOMP Workshop Proceedings LNCS 9338, abstracts and contents are visible at the Springer Website: <http://www.springer.com/de/book/9783319242484>.

The ERCIM/ARTEMIS/Euromicro Special Session TET-DEC (Teaching, Education and Training for Dependable Embedded Cyber-Physical Systems) at SEAA/DSD 2015 took place in Funchal, Madeira, Portugal, August 26-28. The special session covered two time slots on Thursday with five presentations and a concluding plenary discussion. In the first session slot the presentations focused partly on so-called “E&T use Cases” in ARTEMIS projects and their impact on industrial and university education and training (first session):

An introduction to the topic and an overview was given by Erwin Schoitsch (*Introduction to TET-DEC Session - An E&T Use Case in European ARTEMIS projects*), followed by “Reuse in Safety Critical Systems: Educational Use Case Final Results” by Miren Illarramendi Rezabal, Leire Etxeberria and Xabier Elkorbarrutia Letona from Mondragon University.

The second session discussed more general concepts how to teach certain topics:

- *What Training is Needed by Practicing Engineers Who Create Cyberphysical Systems?* (Christopher Scaffidi),
- *Teaching Software Safety to Master Students* (Clara Benac Earle, Ana María Fernández-Soriano, Lars-Ake Fredlund and Elena Gómez-Martínez) and
- *Applying property-based testing in teaching safety-critical system programming* (Lars-Ake Fredlund, Angel Herranz and Julio Mariño).

The plenary discussion brought some new insights and recommendations how to successfully motivate and engage in teaching and education and motivation towards embedded CPS, with input from overseas (US) as well which provided different views. One recommendation was to make industry interested, focus on existing work in connection with the training contents so industry benefits from the outputs of training more directly as project outputs.

Proceedings have been published by IEEE CPS and are available via IEEE Explore. Details are available on request from [erwin.schoitsch@ait.ac.at](mailto:erwin.schoitsch@ait.ac.at).



## V. ADVANCED SAFETY IN AUTOMOTIVE APPLICATIONS



Stefan Berger,  
Infineon Austria AG

On 02 July 2015 a face-to-face meeting between the two partners IFAT and AVL took place in Graz in order to discuss the further procedure as well as the ongoing good collaboration also in *WP7 Automotive applications*. The meeting constituted a follow-up appointment to the meeting in Villach on 23 February 2016 where the two project partners had decided to cooperate in the task *T7.3 Design and validation of next generation hybrid powertrain/E-Drive* in which IFAT had not been mentioned to contribute in the beginning of the project.

In the course of this new cooperation, the safety topics from WP4 are brought into WP6 and WP7 whereas the goal is to develop the two parts (1) hardware towards safety and (2) safety development process. During the meeting in July, the before agreed on strategy was further developed by Stefan Berger (IFAT) and his team giving an overview about their EMC<sup>2</sup> activities in the field of power supply and safety in cooperation with Eric Armengaud (AVL) presenting the current Use Case status. Besides safety engineering for AURIX and especially for the power management system, IFAT pursues the target of creating a safety process and – argumentation and the company concentrates on verification and validation on hardware level.

Together with AVL, the partners came up with challenges in the safety argumentation. First, the difficulty of providing enough transparency in the development over the different teams/institutions to build a safety argumentation while addressing possible confidentiality issues was discussed. Second, managing the complexity of the system and especially the large number of expertise required constitutes a challenge. All of the just mentioned challenges as well as the common interests will be closer looked at in the course of the IFAT-AVL-cooperation in EMC<sup>2</sup>.

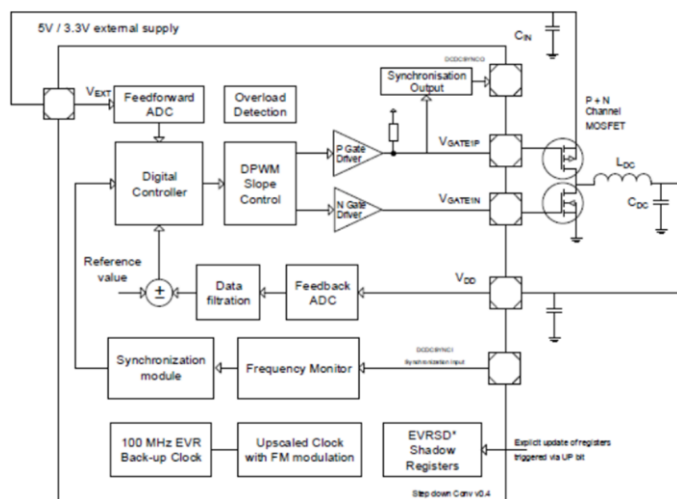

Step-Down Regulator

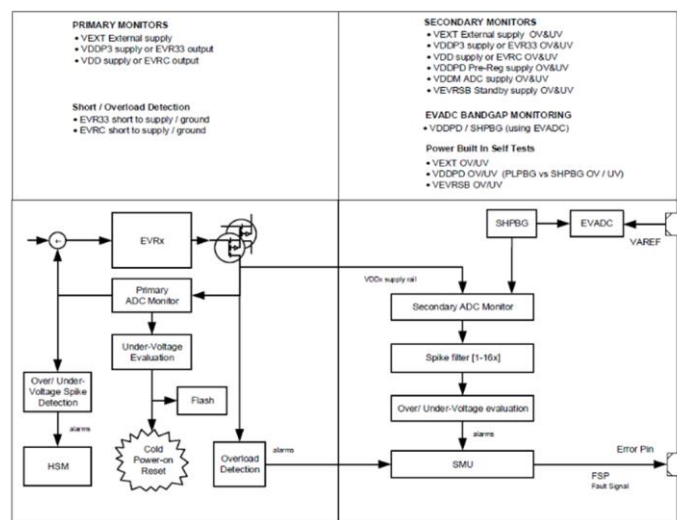

Power Supply Levels and Voltage Monitoring

Coming back to the safety-issue, IFAT-internal synchronization, between the company's two sites in Villach and Graz, took place. During a brainstorming session leading to a discussion about and resulting in the evaluation of common points of reference, the two sites finally came to the decision to strengthen their cooperation on the area of monitoring the secure functions of the Time-of-Flight (ToF) camera. This is important since safety can be endangered through the current spike caused by the ToF-exposure unit which can lead to a slump in the power supply voltage.

In this context, AURIX can be used in order to control the ToF power supply voltage as well as the so-called ToF-“1





am alive”-pins. By including safety aspects into the ToF approach, the collaboration between WP4 and WP6 can

be strengthened which in turn will also bring benefits for other work packages and thus the consortium in the end.

## VI. EMC<sup>2</sup> GARONNE VEHICLES AT ITS WORLD CONGRESS IN BORDEAUX



Dave Marples, Technolution

At the ITS World Conference in Bordeaux, October 2015, Technolution successfully launched their Garonne initiative, named after the river running through the city. Garonne exploits EMC<sup>2</sup> principles to deliver a mixed criticality, multiple Operating System infrastructure on model vehicles.

These models are used to experiment with both Advanced Driver Assistance Services (ADAS) and Autonomous Driving (AD) functionality and are analogues of full size vehicles.

The use of models allows experimenters to take more risks than is possible with full size autonomous vehicles. The philosophy is that you can learn a lot from vehicles that crash, and using models allows the cost of those crashes to be minimised through the use of scale components and technologies such as 3D printing. The vehicles can operate either fully autonomously or a human can 'drive' one of them via a remote telemetry link.

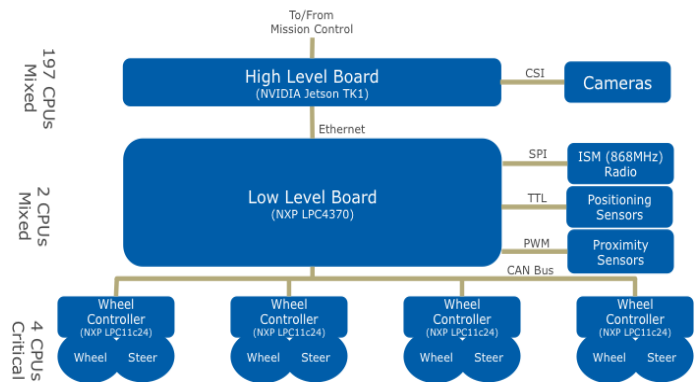
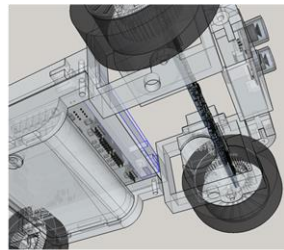

Garonne vehicles architecture

The current Garonne vehicles feature an ARM M0 CPU per wheel (delivering both drive and steering) connected via a CAN bus to a Low Level Board which delivers basic co-ordination functionality via a ARM M4 CPU integrated with two ARM M0s. This subsystem is driven by a High Level Board over an Ethernet connection. The high level board features an NVIDIA K1 CPU with 5 ARM A15 cores and 192 Kepler GPUs delivering in the order of 300 GFLOPS.

In Bordeaux a collection of four vehicles drove autonomously for a total of four days on a 4x3m 'table', following instructions delivered to them from a tablet over a 868MHz link emulating ITS-G5 communication.



Technolution booth and Garonne vehicles, ITS Bordeaux





The Garonne platform is expected to form the basis for the overall EMC2 WP7.1 demonstrator with other partners integrating their deliverables onto it, starting

with the TU/e FPGA-based CPU which will replace the Tegra K1 in the next iteration in Q1 2016.

## VII. EMC<sup>2</sup> AT HIPEAC 2016 – 2<sup>ND</sup> WORKSHOP ON MIXED CRITICALITY APPLICATIONS AND IMPLEMENTATION APPROACHES



Albert Cohen, INRIA

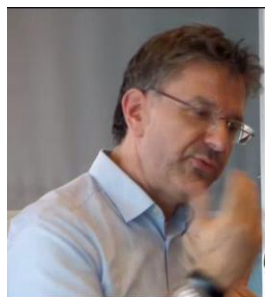

Mladen Berekovic, TUBS

EMC<sup>2</sup> organises a workshop at [HIPEAC conference](#) to take place in Prague, Czech Republic from Monday, January 18 to Wednesday, January 20, 2016. The EMC<sup>2</sup> workshop will take place on Wednesday, Jan. 20.

Embedded multicore systems integrate more and more functionalities on a single chip. These systems tend to run applications of different criticality levels with increasingly dynamic requirements. In addition, dynamic aspects of application behaviour provide more leeway to improve performance on multicores, which could lead to a significant and potentially unacceptable increase of engineering and certification costs.

This second issue of the workshop will provide a vertical perspective on mixed-critical applications, discussing emerging challenges from non-functional requirements to platform integration. Thanks to the success of the first workshop in Amsterdam, associated with HIPEAC 2015, it will be a full-day workshop with invited presentations and from inside and outside the project's consortium:

- Invited Talk: Tulio Vardanega. Sparse cogitations on (some) MCS challenges
- Session 1: Simulation, Modeling and Tools for Mixed Criticality

- Kees Goossens(TU/e) . Virtual Execution Platforms for Real-Time Control in Mixed Time-Criticality Systems
- Frank Oppenheimer (OFFIS): Platform-aware Modelling for Mixed-Critical Applications
- Patrick Siegl, Rainer Buchty, Bastian Farkas, Sven Alexander Horsinka, Rolf Meyer, Jan Wagner, Mladen Berekovic (TUBS): The Past, Present and Future of the Open-Source Virtual Platform SoCRocket
- Alberto Sillitti Paolo Ciancarini, Francesco Poggi, Davide Rossi (CINI): Metrics for Defects Prediction in Multi-Core Cyber-Physical Systems
- Invited Talk: Amaury Graillat (Kalray). MPPA and time-predictable certified parallel systems
- Session 2: Applications and Use Cases
  - Jiri Kadlec (UTIA), Zdenek Pohl (UTIA), Lukas Kohout (UTIA) Mark Honmam (Sundance), Flemming Christensen (Sundance): Xilinx SDSoc for acceleration of real-time Video Processing on custom ZYNQ modules. The demo will also be shown at the Sundance booth.
  - George Dimitrakopoulos (HUA): Sustainable mobility in smart cities: "achievements and challenges"
- Session 3: Systems Analysis & Tools
  - Sergio Saez (Instituto Tecnológico de Informática) and Jorge Real (Universitat Politècnica de València): Mixed-Criticality Real-Time Systems based on Time-Triggered and Fixed-Priority Scheduling
  - Danilo Andreotti (Thales Alenia Space), Fabio Federici (Univ. L'Aquila), Vittoriano Muttillio (Univ L'Aquila), Dario Pascucci (Thales Alenia Space), Luigi Pomante (Univ. L'Aquila), Giacomo Valente (Univ. L'Aquila): Analysis of paravirtualization tools supporting isolation in multicore, mixed-criticality aerospace systems
  - Christoph Dropmann (Fraunhofer IESE): An automated interference identification approach





## VIII. EMC<sup>2</sup> SUMMIT 2016 – CALL FOR PAPERS

**“Embedded Multi-Core Systems for Mixed Criticality Applications in Dynamic and Changeable Real-Time Environments” at CPS Week 2016, Emperor’s Palace (Hofburg), Vienna, Austria, April 11, 2016**



Erwin Schoitsch, AIT

**organized by**

**Local Organizer and IPC Chair:**

Dipl.-Ing. Erwin Schoitsch

([Erwin.Schoitsch@ait.ac.at](mailto:Erwin.Schoitsch@ait.ac.at))

Austrian Institute of Technology  
GmbH, Austria

**Co-organizers and IPC Co-Chairs:**

Dr. George Dimitrakopoulos ([gdimitra@hua.gr](mailto:gdimitra@hua.gr))

Harokopio University of Athens, Greece

Dr. Daniel Schneider,

([Daniel.Schneider@iese.fraunhofer.de](mailto:Daniel.Schneider@iese.fraunhofer.de)),

Fraunhofer Institute, Germany

Dr. Werner Weber ([Werner.weber@infineon.com](mailto:Werner.weber@infineon.com)),

Infineon Technologies AG, Germany

*The EMC<sup>2</sup> Summit is open to all CPS week participants free of charge; separate participation to the Summit only will be possible against a separate charge (to be announced).*

### Call for Papers

#### Motivation and Theme:

EMC<sup>2</sup> – “Embedded Multi-Core systems for Mixed Criticality applications in dynamic and changeable real-time environments” is an ARTEMIS/ECSEL Joint Undertaking project in the ARTEMIS Innovation Pilot Programme “Computing platforms for embedded systems” (AIPP5). EMC<sup>2</sup> is a project of 100 partners of embedded industry and research from 19 European countries with an effort of about 800 person years and a total budget of more than 90 million Euro, which started April 1, 2014 and will finish 2017. For details, see <http://www.artemis-emc2.eu/>.

Cyber-physical systems (CPS) are the key innovation driver to improve almost all mechatronic products with

cheaper and new functionalities. Furthermore, they strongly support today's information society as inter-system communication enabler. Consequently boundaries of application domains are alleviated and ad-hoc connections and interoperability play an increasing role. We have to find solutions for dynamic adaptability in open systems, provides handling of mixed criticality applications under real-time conditions, scalability and utmost flexibility, full scale deployment and management of integrated tool chains, through the entire lifecycle.

At the same time, multi-core and many-core computing platforms are becoming available on the market and provide a breakthrough for system (and application) integration, changing considerably the preconditions for dependable, safe and secure systems with respect to predictability. A major industrial challenge arises from the need to face cost efficient integration of different applications with different levels of safety and security (mixed criticality) on a single computing platform in an open context.

EMC<sup>2</sup> will present work in progress and important intermediate results of the ongoing project (2014 – 2017) and invites researchers and industry to contribute from their ongoing work in the areas addressed and of related projects.

Topics of interest include, but are not limited to:

1. Architectures and platforms for embedded (cyber-physical) systems
2. Application Models and Design Tools for Mixed-Critical, Multi-Core CPS
3. Dynamic runtime environments and services
4. Multi-core hardware architectures and concepts
5. System design platform, tools, models and interoperability
6. Applications of multi-core cyber-physical systems: avionics, automotive, space, cross-domain and other applications
7. Safety and security co-engineering in open dynamic CPS
8. Next generation embedded/cyber-physical systems
9. Standardization, qualification and certification issues of complex critical CPS



### Submission procedure and author instructions:

The papers will be reviewed by at least three reviewers and be published as ERCIM Workshop Proceedings in an open archive (e.g. Open Access repository HAL, <https://hal.archives-ouvertes.fr/ERCIM>). A manuscript submitted to the EMC<sup>2</sup> Summit of CPS-Week 2016 must be in the IEEE double column format with single space 10p fonts and figures included in the text, so the length of the manuscript of 6 - 8 pages long in PDF format can be evaluated. For your convenience you may download the WORD template.doc (A4) from the IEEE website: [http://www.ieee.org/conferences\\_events/conferences/publishing/templates.html](http://www.ieee.org/conferences_events/conferences/publishing/templates.html)

There is a second chance to present a poster (A0 or A1) with a short paper (2-3 pages) which will be published as well.

*The EMC<sup>2</sup> Summit is scientifically co-sponsored by the ERCIM Dependable Embedded Software-intensive Systems Working Group and EWICS TC7 (European Workshop on Industrial Computer Systems, TC7, Safety, Reliability and Security), and co-hosted by the ARTEMIS projects ARROWHEAD, CRYSTAL and the standardization Innovation Action CP-SETIS.*

Please send papers to the IPC chairperson [Erwin.schoitsch@ait.ac.at](mailto:Erwin.schoitsch@ait.ac.at).

### Deadlines:

- Reception of full paper: February 7, 2016
- Paper acceptance notification: February 28, 2016
- Camera ready paper reception: March 10, 2016
- EMC<sup>2</sup> Summit: April 11, 2016

## EMC<sup>2</sup> Impressum

### **Project:**

- EMC2 - Embedded Multi-Core systems for Mixed Criticality applications in dynamic and changeable real-time environments
- ARTEMIS Grant Agreement Number: 621429

### **Project Coordinator:**

Infineon Technologies AG  
 Dr. Werner Weber  
 IFAG BEX RDE RDF  
 Am Campeon 1-12  
 85579 Neubiberg, Germany  
 Contact: [werner.weber@infineon.com](mailto:werner.weber@infineon.com)

### **Editorial:**

Albert Cohen, INRIA  
 Luis Miguel Pinho, CISTER  
 Rafael Zalman, Infineon Technologies AG  
 Contact: [emc2\\_newsletter@list.emdesk.eu](mailto:emc2_newsletter@list.emdesk.eu)

### **Layout, Design:**

Alfred Hoess, Administrative Support

