

Hardware Block Diagram

- **Sensors:**
 - Gyro + Accelerometer + Compass
 - Barometric Pressure/Temperature/Altitude
 - Voltage for Motor and Logic Battery
 - USB-HUB for WLAN, GIMBAL
 - Remote control IF
- **Actors:**
 - USB-HUB for WLAN, GIMBAL
 - PWM Motor control

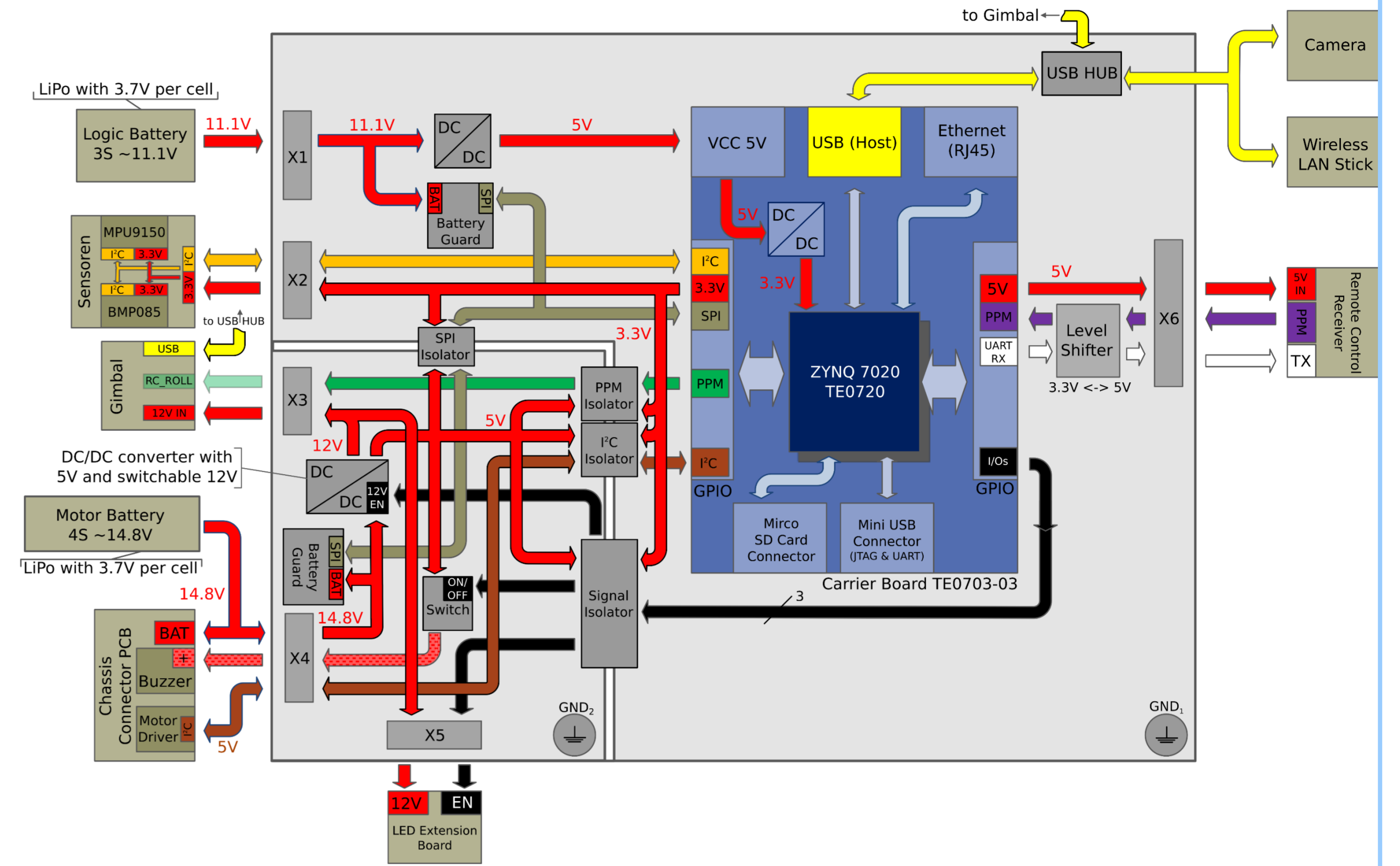

HW/SW Architecture

- Flight and Position control
 - Execution on Soft-Cores in FPGA
 - Bare metal, no OS support
 - Interfaces for I2C, PPM and GPIO used
- Object tracking
 - Execution on Dual ARM-Core
 - Needs Linux as OS
 - Multimedia Libraries
 - Needs interfaces USB und Network
- Communication via Dual-Ported BRAM

Mapping

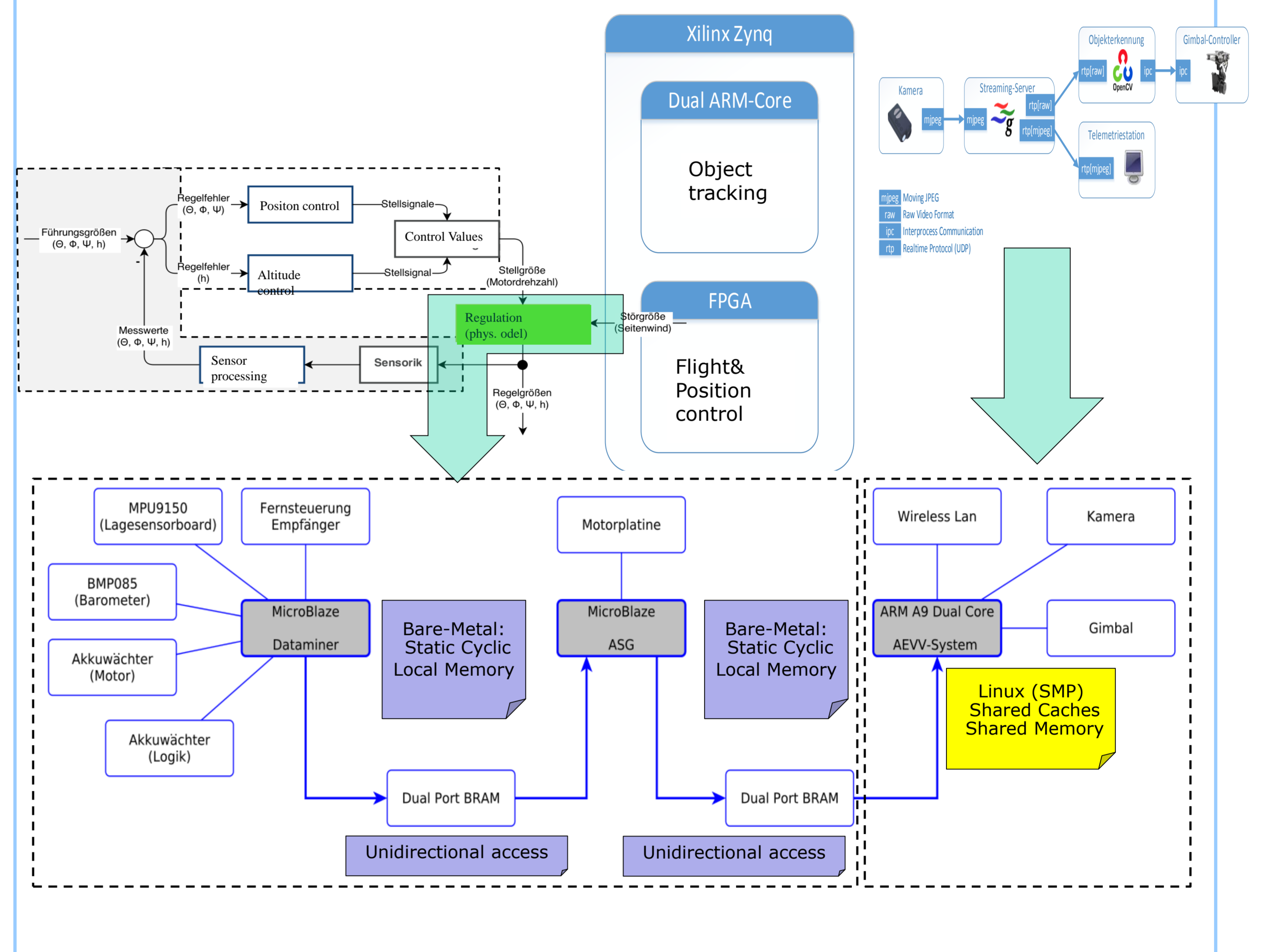

Integrated Electronic System

- ZYNC 7020 (dual ARM+FPGA)
- Motor control driver
- LED/Buzzer control
- Battery control
- Gimbal

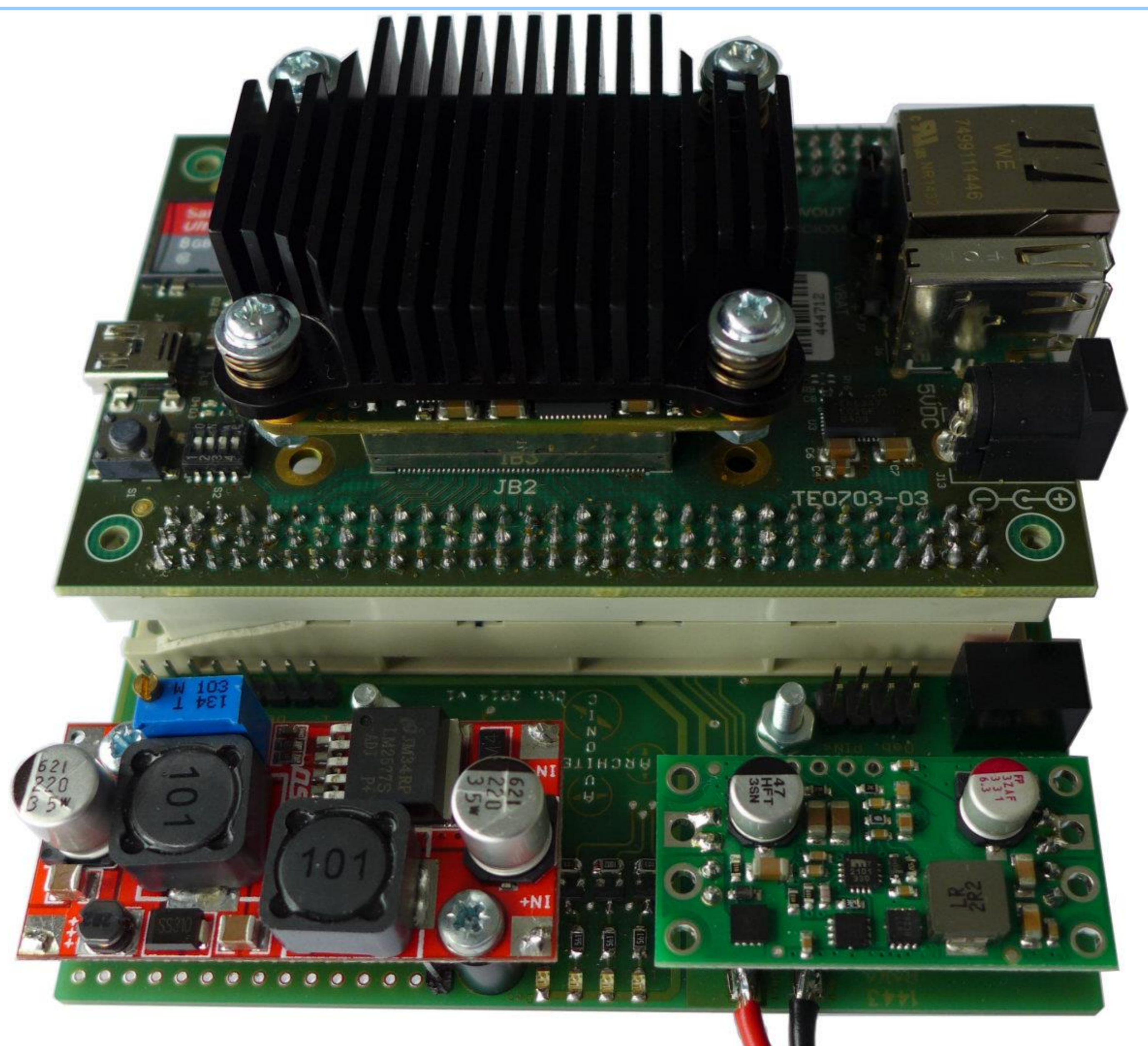

Contributing Partners: